

1. Description.

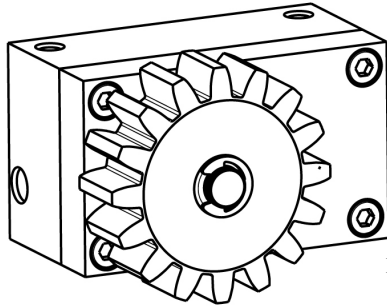

Fig.1

CONTROLGIR 7 - APE - 147/4004

The CONTROLGIR M4 Z16 rotating brake has been designed to regulate and control the speed of the door or gate in installations when the door or gate is not hung vertically and opening or closing must be controlled against gravity for safety reasons. The shock absorber only provides resistance in one rotational direction; the opposite direction has free movement. This accessory can be used on automatic doors or gates with a module 4 rack. CONTROLGIR is made of anticorrosive materials, aimed to be used outdoors.

2. Dimensions and technical characteristics.

TECHNICAL CHARACTERISTICS	CONTROLGIR
COG MODULE	M4
N° of TEETH	Z16
TYPE OF LIQUID	SILICONE 3000
SERVICE TEMPERATURE	-15°C +70°C
MAXIMUM WEIGHT	7 NM
BRAKE DIRECTION	LEFT OR RIGHT
LOAD ADJUSTMENT	YES

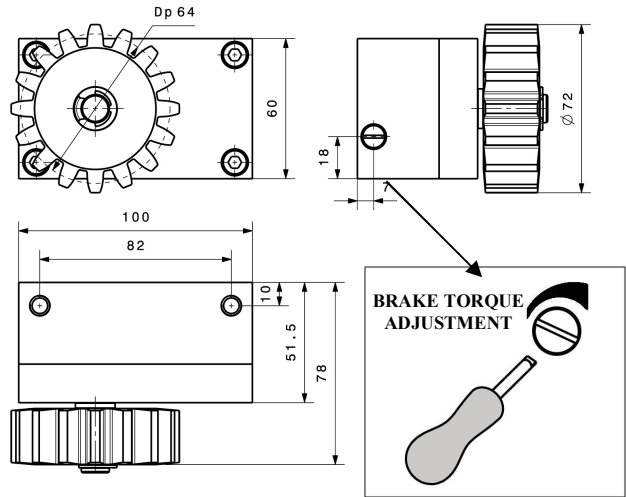

Fig.2

3. Assembly instructions.

3.1 Changing brake direction.

To change the brake direction you must remove the cir-clip (Fig.3), remove the cog (Fig.4) turn it round as per (Fig.5). Replace the cir-clip.

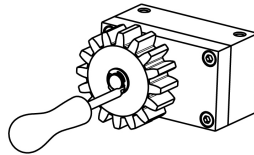

Fig.3

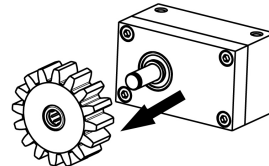

Fig.4

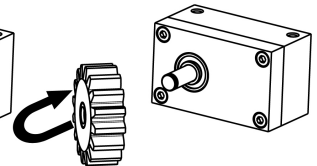

Fig.5

3.2 Assembly.

CONTROLGIR M4 must be placed as close as possible to the control mechanism (Fig.6) and adjusted to the correct height, leaving one millimeter of clearance between the cog and the rack (Fig.7).

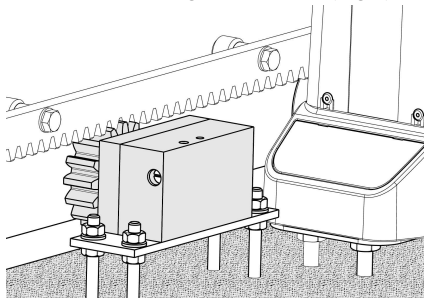

Fig.6

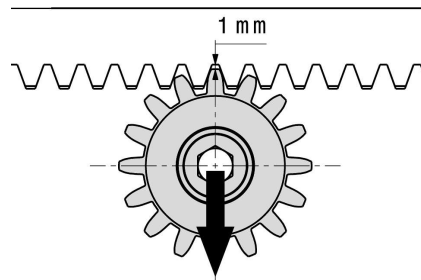

Fig.7

3.3 Calculation.

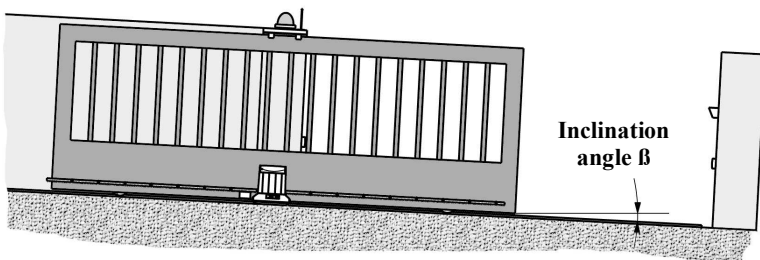

Fig.8

$$M \text{ [Nm]} = P \times \sin \beta \times 0.032$$

P = weight of the door in Newton (9.8N=1Kg)

β = inclination in degrees

Example for calculation:

CONTROLGIR M4 can be used on doors which weigh 400kg and have an inclination of 3°?

$$P = 9.8 \times 400\text{kg} = 3920 \text{ Newton}$$

$$M = 3920 \text{ Newton} \times \sin 3^\circ \times 0.032 = 6.56 \text{ Nm}$$

6.56 Nm is less than 7 Nm (maximum allowed), and is thus the brake would be suitable for this installation.